



System Interface Products

PODM – Precision Oscillator - Dual MuxTees



10MHz Master Oscillator plus Dual Mux/Tees in one package

How to order a Precision Oscillator Dual Mux/Tees (PODM)

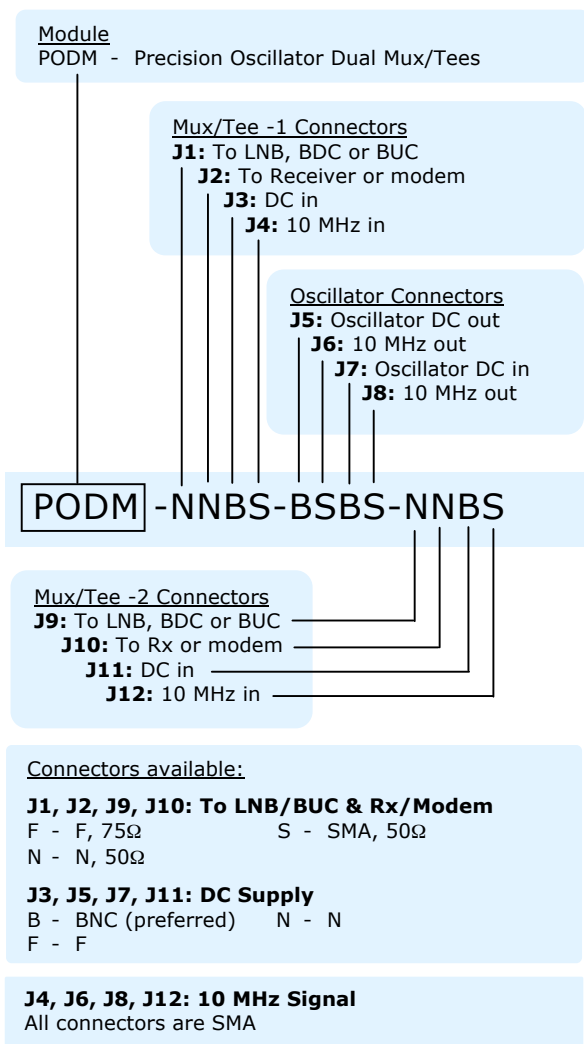

BNC-to-pigtail adapters and BNC-to-binding post adapters sold separately. See SIP price list for part number and price.

PODM Features

Ovenized Oscillator (OCXO)

- Exceptionally low phase noise -160 dBc/Hz @ 1 kHz
- Exceptionally low drift, 0.05ppm, 0 to 50°C
- Exceptionally stable, $\pm 1 \times 10^{-9}$ per day after 30 days
- High output level for service as master system oscillator
- Sine wave purity, low harmonic content
- Red LED extinguishes when ovenized oscillator reaches stable operating equilibrium

Mux/Tee (as secondary modules)

- Highpass filtered L band, rolloff below 900 MHz, flat 950 thru 2900 MHz
- Very low bandpass ripple
- Very high Rx to 10MHz port isolation, no leakage back to rx
- Superior Input and Output VSWR

Functional

- Will operate with LNBs, BDCs, VSATs, BUCs, and Modems

Structural

- Machined from solid aluminum billet for strength and stability
- Allodyne finish for corrosion protection and excellent RF shielding/grounding
- Connectors are 'O' ring sealed for weather resistant operation

Power Supply

Orbital advises that a separate power supply be used for each power input (Oscillator and dual packages) as one power supply for all can cause extraneous signals to be transferred to the Oscillator, which can degrade its performance.

Doug Macdonald
 Tel: (647) 992-1210
doug.macdonald@orbitalresearch.net

David Zuvic
 Tel: (604) 856-0305,
dzuvic@orbitalresearch.net

www.orbitalresearch.net

System Interface Product: PODM - Specifications

**PODM Block Diagram
Mechanical Dimensions +
Functional Block Diagram
Viewed as if dismantled**

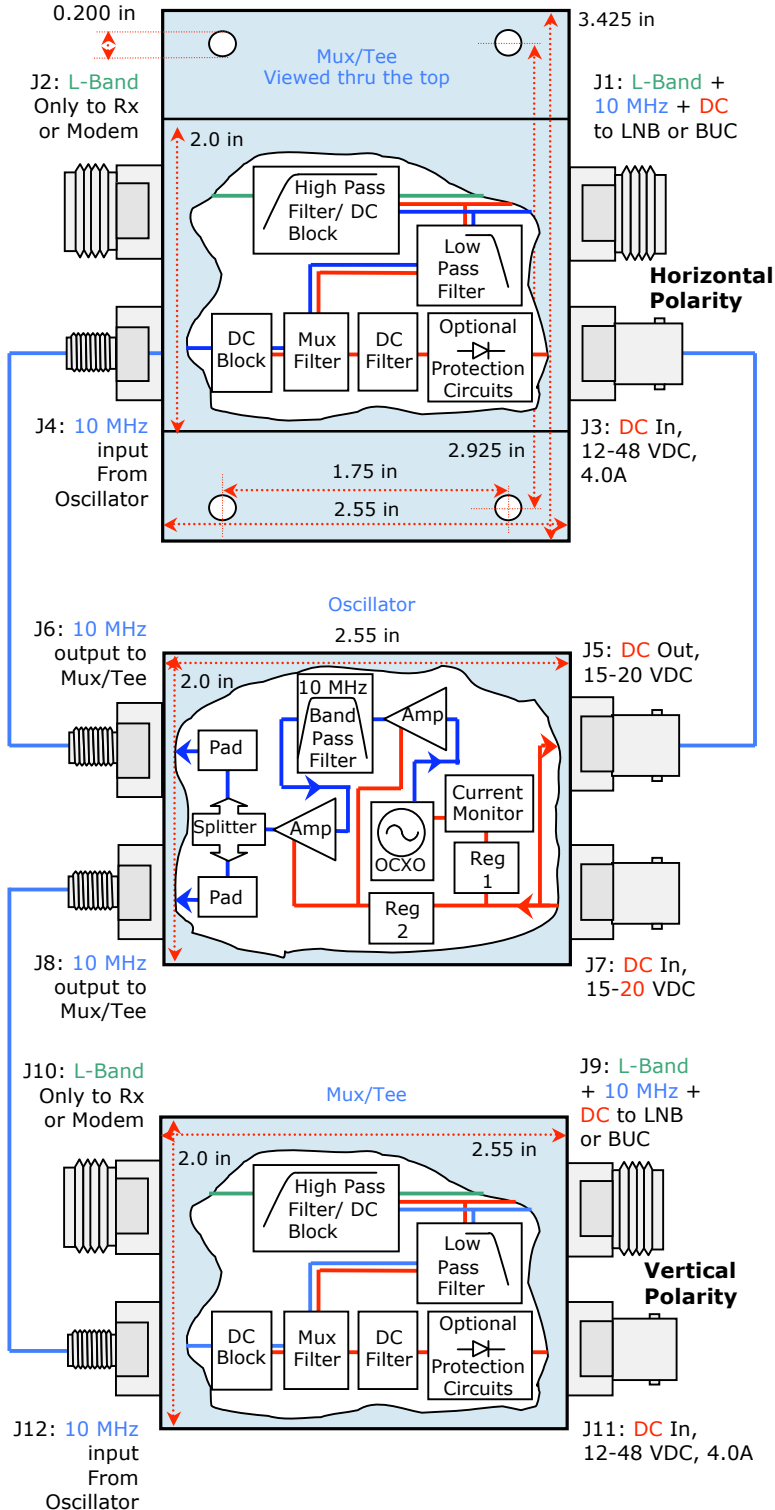

Mux/Tee

L Band

Bandpass: 900 to 2100 MHz
 Thru Loss: 0.5 dB maximum
 Ripple: ± 0.3 dB maximum
 Input VSWR: 1.3 : 1 maximum
 Output VSWR: 1.3 : 1 maximum

10 MHz

Passband: 1-100 MHz (3 dB down)
 Thru Loss: 0.2 dB 10 MHz to LNB port
 Isolation: >90 dB 10 MHz to Rx port

DC

Filtering: Hash filter, low pass filter
 Resistance: 0.132 ohms (average)

10 MHz Oscillator

Frequency: 10 MHz
 Level: +2 dBm
 Stability: $\pm 5 \times 10^{-8}$, 0 to +50°C
 Aging: $\pm 1 \times 10^{-9}$ per day after 30 days
 $\pm 5 \times 10^{-7}$ per year after 180 days
 Phase Noise:
 10Hz -120 dBc/Hz
 100Hz -145 dBc/Hz
 1kHz -160 dBc/Hz
 10kHz -165 dBc/Hz
 100kHz -165 dBc/Hz

Power Specifications

Oscillator

Input DC Voltage: +15 to +20 VDC supplied via DC input connector
 Current Drain: 350 mA max (warm-up)
 100 mA nominal (after warm-up)

Mux/Tees

Input DC Voltage: Passive Device. No power required
 Power Capacity: 12 to 48 VDC - 4.0A

Mechanical Specifications

Measurements: Tolerance ± 0.005 in.
 Size (case): 3.425l x 2.55w x 2.725h in.
 Weight: 15 oz
 Paint / Colour: Anodized Blue
 MIL-STD-595

Environmental Specifications

Operating Temp: 0 to +50° Celsius
 Relative Humidity: Up to 100% condensation and frost

Power Supply (not included with PODM)

See: PS1 brochure for North America
 PS2 brochure for Global

Orbital Research Ltd. designs and builds products for satellite communications applications. Copyright © 2011 Genie in the Bottle Enterprises Inc. All rights reserved. Specifications subject to change without notice.