

## System Interface Products

### MODM – Master Oscillator - Dual Modules



## 10MHz Master Oscillator plus Dual Mux/Tees in one package

### How to order a Master Oscillator Dual Module (MODM)

#### Module

MODM - Master Oscillator Dual Module

#### Mux/Tee -1 Connectors

**J1:** To LNB, BDC or BUC  
**J2:** To Receiver or modem  
**J3:** DC in  
**J4:** 10 MHz in

#### 10MHz Oscillator Connectors

**J5:** Oscillator DC out  
**J6:** 10 MHz out  
**J7:** Oscillator DC in  
**J8:** 10 MHz out

MODM-NNBS-BSBS-NNBS

#### Mux/Tee -2 Connectors

**J9:** To LNB, BDC or BUC  
**J10:** To Rx or modem  
**J11:** DC in  
**J12:** 10 MHz in

#### Connectors available:

#### J1, J2, J9, J10: L-Band: To LNB/BUC & Rx/Modem

F - F, 75Ω                      S - SMA, 50Ω  
 N - N, 50Ω

#### J3, J5, J7, J11: DC Supply

B - BNC (preferred)    N - N  
 F - F

#### J4, J6, J8, J12: 10 MHz Signal

All connectors are SMA

BNC-to-pigtail adapters and BNC-to-binding post adapters sold separately. See SIP price list for part number and price.

### MODM Features

#### Oscillator

- Great phase noise: -147 dBc/Hz @ 1 kHz
- Excellent stability, long and short term
- Sine wave purity, low harmonic content

#### Mux/Tees (high power version)

- Highpass filtered L band, rolloff below 900 MHz, flat 950 thru 2900 MHz
- Low thru loss from 10 MHz input to LNB
- Any in, Any out Impedance transforms (eg. 75 Ω in, 50 Ω out)
- Very low bandpass ripple
- Very low L band through loss
- Very high Rx to 10MHz port isolation, no leakage back to rx
- Superior Input and Output VSWR
- Protects phase noise performance

#### Functional

- Will operate with LNBS, BDCs, VSATs, BUCs, and Modems

#### Structural

- Machined from solid aluminum billet for strength and stability
- Allodyne finish for corrosion protection and excellent RF shielding/grounding
- Connectors are 'O' ring sealed for weather resistant operation

#### Oscillator Power Supply

The Orbital MODM Oscillator has a second, feedthrough connector to allow the input DC to be fed through to one of the Mux/Tees to power the LNB or BUC attached.

#### Ordering

The part number includes each connector on the MODM. Some of the connectors have only one option but including them all seems to decrease confusion when ordering.

14239 Marine Drive,  
 White Rock, BC  
 V4B-1A9 Canada

Unit 126 – 1160 Yew Ave,  
 Blaine, WA  
 98230, USA

Tel: (604) 856-0305, Fax: (604) 856-0315  
 davidzovic@orbitalresearch.net  
 www.orbitalresearch.net

# System Interface Product: MODM - Specifications

**MODM Block Diagram  
Mechanical Dimensions +  
Functional Block Diagram  
Viewed as if dismantled**

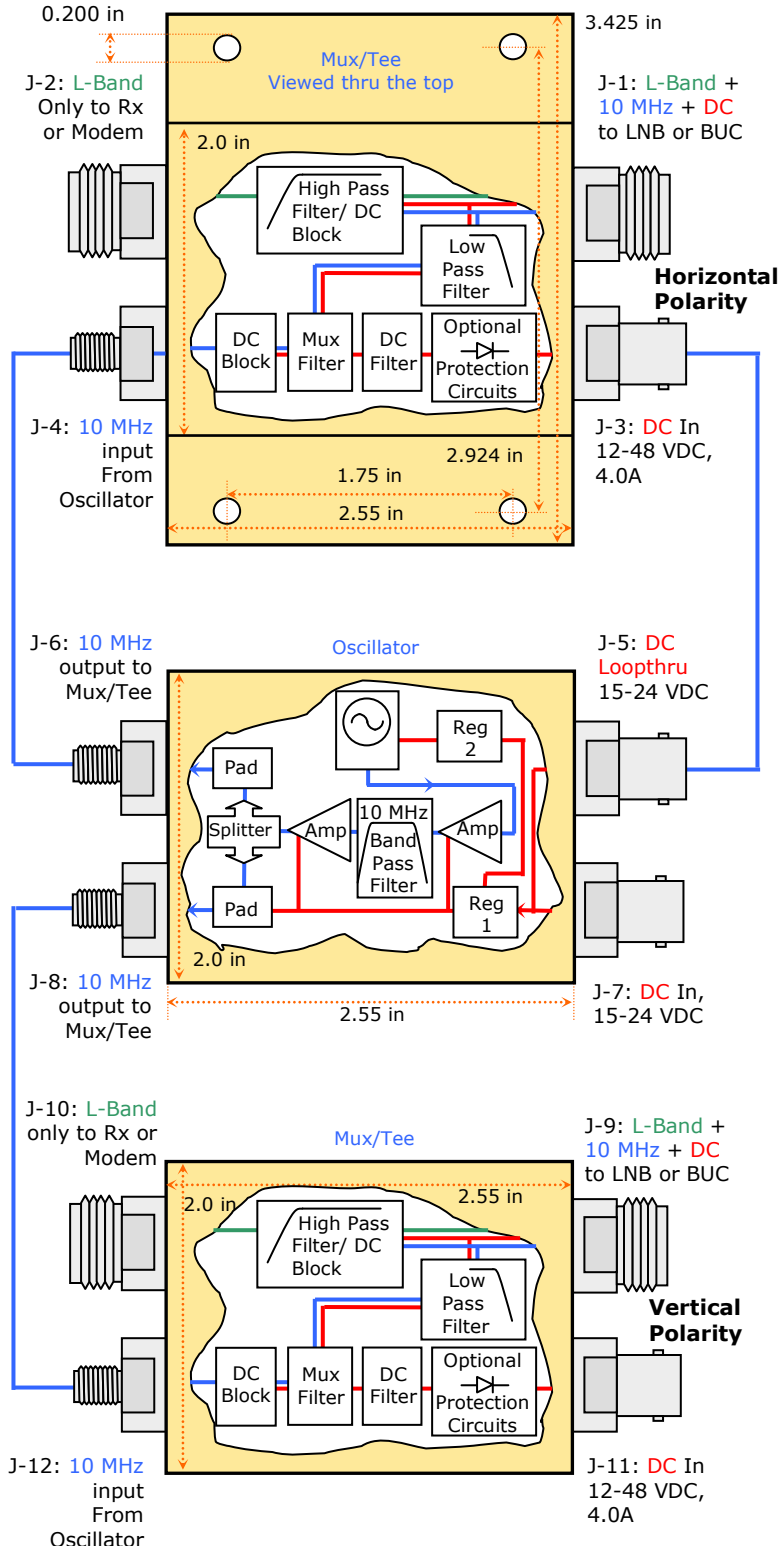

## Mux/Tee

### L Band

Bandpass: 900 to 2100 MHz  
Thru Loss: 0.5 dB maximum  
Ripple:  $\pm 0.3$  dB maximum  
Input VSWR: 1.3 : 1 maximum  
Output VSWR: 1.3 : 1 maximum

### 10 MHz

Passband: 1-100 MHz (3 dB down)  
Thru Loss: 0.1 dB 10 MHz to LNB port  
Isolation:  $> 90$  dB 10 MHz to Rx port

### DC

Filtering: Hash filter, low pass filter  
Resistance: 0.132 ohms (average)

## 10 MHz Oscillator

Frequency: 10 MHz  
Level: +2 dBm  
Stability:  $\pm 1.5 \times 10^{-7}$ , 0 to +40°C  
Aging:  $\pm 1 \times 10^{-6}$  per day after 30 days  
 $\pm 5 \times 10^{-6}$  per year after 180 days  
Phase Noise:  
100Hz -130 dBc/Hz  
1kHz -147 dBc/Hz  
10kHz -148 dBc/Hz  
100kHz -148 dBc/Hz

## Power Specifications

### Oscillator

Input DC Voltage: +15 to +24 V supplied via DC input connector  
Current Drain: Approximately 100 mA

### Mux/Tees

Input DC Voltage: +12 to +48V supplied via DC input connector  
Current Capacity: 4.0 Amps

## Mechanical Specifications

Measurements: Tolerance  $\pm 0.005$  in.  
Size: 3.425l x 2.55w x 2.45h in.  
Weight: 15 oz  
Paint / Colour: Gold Allodyne finish  
Mounting holes: 3/8" (5mm)  
Accepts standard rackmounting screws: 10/32 or 10/34

## Environmental Specifications

Operating Temp: 0 to +40° Celsius  
Relative Humidity: Up to 100% condensation and frost

## Power Supply (not included with MODM)

See: PS1 brochure for North America  
PS2 brochure for Global

Orbital Research Ltd. designs and builds products for satellite communications applications. Website: [www.orbitalresearch.net](http://www.orbitalresearch.net). Copyright © 2008 Orbital Research Ltd. All rights reserved. Specifications subject to change without notice.