

# System Interface Products

## MT 433 Mux Tee



10MHz Multiplexer, M&C channel, and Bias Tee in one package

### How to order a MT433 Mux/Tee

Module  
MT433 - Hi Power Mux/Tee

J-1: To LNB, BDC or BUC

J-2: To Rx or Modem

J-3: To DC Supply

J-4: To 10MHz Source

MT433-NNBS-D9

J-5: To 433MHz Source

#### Connectors available:

##### J1, J2: L-Band to LNB/BUC & Rx/Modem

N - N, 50Ω                      S - SMA, 50Ω  
F - F, 75Ω (not avail. for hi power to BUC)

##### J3: DC Supply

B - BNC (preferred)      FT - Feedthrough  
N - N

##### J4: 10MHz

B - BNC (industry standard)  
S - SMA (recommended for outdoor use)  
N - N

##### J5: 433 MHz I/O Port

D9 - DB9

BNC-to-pigtail adapters and BNC-to-binding post adapters sold separately. See SIP price list for part number and price.

### Orbital Design:

Orbital Research introduces a System Interface Product (SIP) that adds a data channel capability to our conventional Mux/Tee product. The MT 433 enables M&C information to be transmitted from the indoor unit to the outdoor unit simultaneously with DC, reference and L-band IF signals. This eliminates the need for separate M&C cable connections.

### Orbital Features:

#### Specifications

- 433 MHz control channel port, -60 to -90 dBm, 50 ohms
- 11 MHz data channel bandwidth, (19.2 kbs data rate min)
- Highpass filtered L band:
  - rolloff below 900MHz, flat 950 thru 2100MHz
  - Assures DC block to Rx port and 10 MHz port
- Filtered 10MHz
- low thru loss from 10 MHz input to LNB
- Lowpass filtered DC, 4.0A capacity (12 to 48V) standard - for LNBs or transmitters
- Any combination of 50Ω and 75Ω in/out Impedance transforms, (eg. 75Ω J-1 to 50Ω J-2)
- Very low passband ripple and insertion loss
- Very high Rx port to 10MHz port isolation, no leakage back to rx
- Superior Input and Output VSWR
- Will not degrade phase noise performance

#### Functional

- Will operate with LNBs, BDCs, VSATs, BUCs, and Modems
- Connectors O ring sealed for weather resistant operation
- Will not cause loss of lock
- Will not impair bit error rate

#### Structural

- Machined from solid aluminum block for strength, stability and endurance
- Allodyne finish for corrosion protection and excellent RF shielding/grounding
- Excellent shielding and grounding
- 'Back O Rack' mounting bracket for ease of installation and lead dress
- Fewer cables and connectors yield less signal degradation
- Reduces the mess of cables at the back of the rack

14239 Marine Drive,  
White Rock, BC  
V4B-1A9 Canada

Unit 126 - 1160 Yew Ave,  
Blaine, WA  
98230, USA

Tel: (604) 856-0305, Fax: (604) 856-0315  
davidzovic@orbitalresearch.net  
www.orbitalresearch.net

# System Interface Product: MT 433 Mux Tee Specifications

Orbital MT433 Mux / Tee  
Mechanical Dimensions +  
Functional Block Diagram  
Viewed from the top

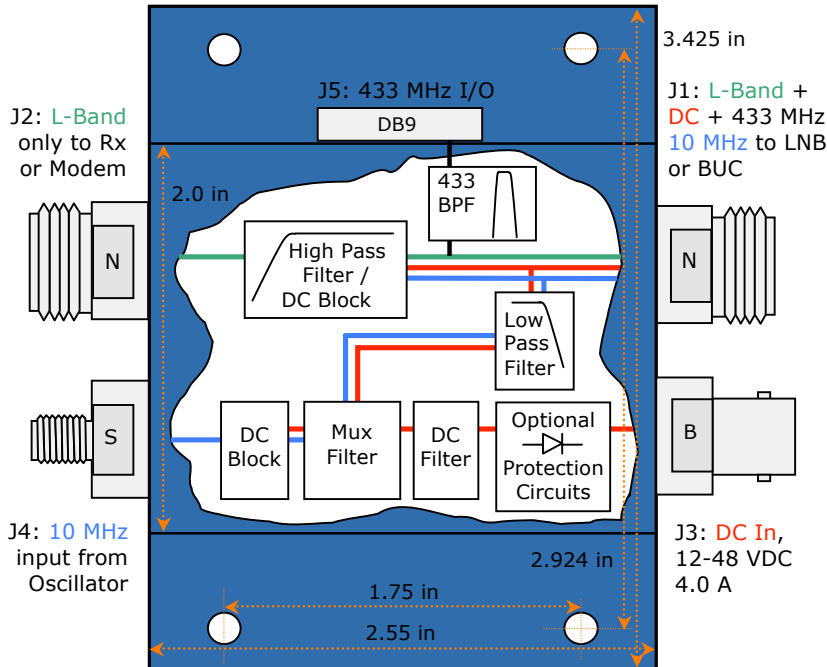

## Electrical Specifications

### L Band

Bandpass:	900 to 2100 MHz
Thru Loss:	0.5 dB maximum
Ripple:	±0.3 dB maximum
I/O VSWR:	1.3 : 1 maximum

### 433 MHz I/O

Bandpass:	11 MHz
Thru Loss:	22 dB maximum
Ripple:	±0.5 dB maximum
Input VSWR:	1.3 : 1 maximum

### 10 MHz

Passband:	1-100 MHz (3 dB down)
Thru Loss:	0.3 dB 10 MHz to LNB port
Isolation:	>90 dB 10 MHz to Rx port

### DC

Filtering:	Hash filter, low pass filter
------------	------------------------------

## Mechanical Specifications

LNB/BUC Interface:	F, N or SMA
Rx/Modem Interface:	F, N or SMA
433 MHz I/O Port:	DB9
Size:	2.55 x 3.43 x 0.85 in.
Weight:	5 oz
Paint / Colour:	Blue Allodyne finish

Standard Mux/Tees are not designed for Satellite applications. They are very simple circuits.

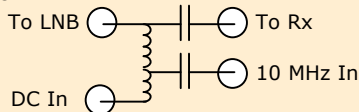

Orbital's Mux/Tee is designed specifically for sensitive Satellite applications. We filter and condition the line between LNB and receiver so your equipment works as it should. The 10MHz goes only to the LNB and is highly isolated from the receiver.

Each connector type has an impedance of either 50 or 75 ohms. Orbital uses 1 of 4 distinct boards to achieve the appropriate impedance transform between the LNB/BUC interface and Rx/Modem interface:

- V1 - 50Ω to LNB/BUC, 50Ω to Rx/modem
- V2 - 75Ω to LNB/BUC, 50Ω to Rx/modem
- V3 - 75Ω to LNB/BUC, 75Ω to Rx/modem
- V4 - 50Ω to LNB/BUC, 75Ω to Rx/modem

## Environmental Specifications

Operating Temp:	-40 to +60° Celsius
Relative Humidity:	Up to 100% condensation and frost

## Power Specifications

Input DC Voltage:	Passive Device. No power required
Power Capacity:	12 to 48 VDC - 4.0

## Switching Power Supply

(not included with Oscillator)

See: PS1 brochure for North America  
PS2 brochure for Global

Orbital Research Ltd. designs and builds products for satellite communications applications. Orbital website: [www.orbitalresearch.net](http://www.orbitalresearch.net). Copyright © 2009 Genie in the Bottle Enterprises Inc. All rights reserved. Specifications subject to change without notice.

