



Orbital 5300 Series Ku PLL Modified LNB



40 to 65 dB gain, 250 to 1050 MHz bandwidth, any Ku satellite

How to order an Orbital 5300 Series Ku PLL modified LNB

Frequencies (GHz):

LO	Input	Output	Bandwidth
9.75S	- 10.70 to 11.70	.95 to 1.95	1.000
10.00S	- 10.95 to 11.70	.95 to 1.70	0.750
10.15S	- 11.70 to 12.20	1.55 to 2.05	0.500
10.25S	- 11.20 to 11.70	.95 to 1.45	0.500
10.50S	- 11.45 to 11.95	.95 to 1.45	0.500
10.50S	- 11.45 to 12.20	.95 to 1.70	0.750
10.60S	- 11.70 to 12.20	1.10 to 1.60	0.500
10.75S	- 11.70 to 12.20	.95 to 1.45	0.500
10.75S	- 11.70 to 12.75	.95 to 2.00	1.050
11.25S	- 12.20 to 12.75	.95 to 1.50	0.550
11.30S	- 12.25 to 12.75	.95 to 1.45	0.500

Bandwidth in MHz

'P' Signifies PLL

LNB1075S-1050P-WN60-G

Input Connector
Ku LNB is WR-75

Output Connector
F - F, 75 ohm
N - N, 50 ohm
S - SMA, 50 ohm
T - TNC, 50 ohm

Gain
40 - 40 dB
50 - 50 dB
55 - 55 dB
60 - 60 dB

Enhanced Gain Flatness
G - Temperature Compensated

Orbital Flexibility:

Engineered using the highest quality components insures you from failure due to environmental extremes, such as arctic cold, Saharan heat, and rain-forest humidity. Our LNB is protected from man-made conditions such as shock, vibration, low power, over-voltage, surges, transients, and static discharge. Performance is consistent and replacements will match or exceed your original device. Market leading specifications yield some of the best phase noise on the market.

"Mass-Custom" Solution

Orbital starts with a proven performance product that is extremely well engineered with the development costs amortized over hundreds of thousands of units and the parts costs reduced by volume discounts. We then customize the mass produced LNB into what you want at 1/100 the cost of designing and building from scratch.

Orbital Features:

Custom Engineering

- Begin with the low noise figure of a proven quality LNB
- Optimize Input and Output for superior VSWR
- Modify LO frequencies preserving phase noise and stability
- Modify and tune RF & IF filters for optimum response
- Tune for very low bandpass ripple
- Optimize Gain distribution for your system parameters

Environmental

- O ring sealed connectors for weather resistant operation
- Preserve the environmental engineering of the original LNB

Options

- External DC connector - Feedthrough
- Special Dual DC option via output coax and ext DC port
- Custom alarm options for redundant switch operations
- Full test documentation available
- Temperature Compensated Gain Variation

14239 Marine Drive,
White Rock, BC
V4B-1A9 Canada

1927 Boblett Street,
Blaine, WA
98230, USA

Tel: (604) 856-0305, Fax: (604) 856-0315
davidzovic@orbitalresearch.net
www.orbitalresearch.net

Orbital 5300 Series Ku PLL Modified LNB Specifications

Mechanical Drawing

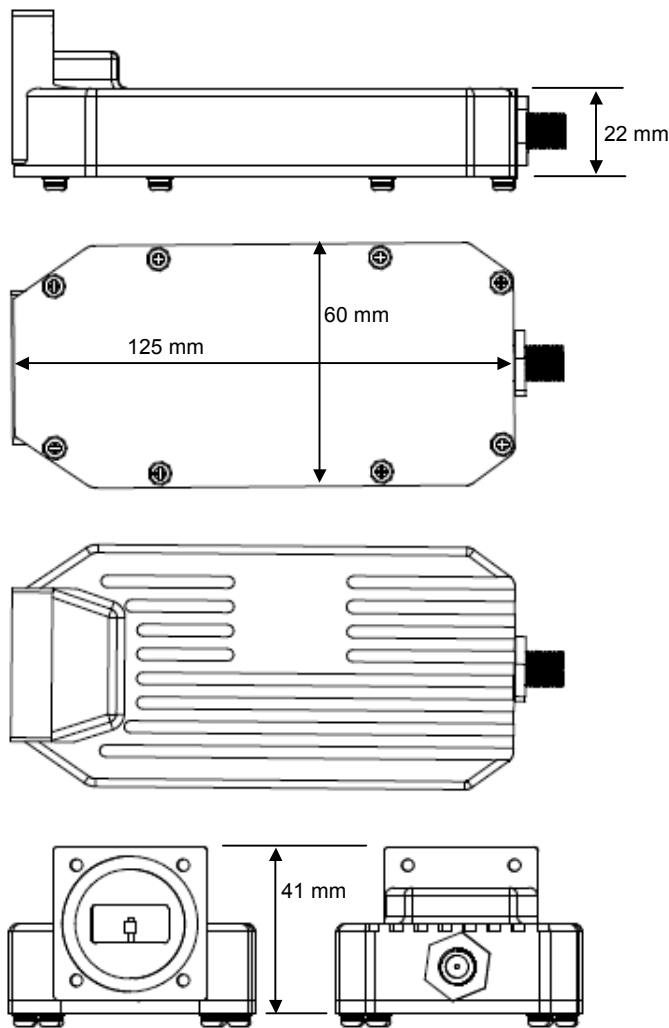

Electrical Specifications

Input

Frequency: Various, over range:
10.7 to 12.75 GHz
Bandwidth: up to 1.05 GHz
Interface: WR-75, Waterproof
Noise Figure: 0.6 dB typical for standard bandwidth
0.8 dB typical for wideband
Ripple: ± 0.5 dB max /36MHz segment
Input VSWR: 2.2 : 1 typical

Output

Bandpass: 950 up to 2100 MHz
Output VSWR: 1.5 : 1 typical
Connector: F standard, N, SMA, TNC optional
LO Stability: ± 5 kHz
LO Phase Noise: 100 Hz offset: -70 dBc/Hz
1 kHz offset: -80 dBc/Hz
10 kHz offset: -85 dBc/Hz
100 kHz offset: -105 dBc/Hz
Compression: +10 dBm min., standard bandwidth
+7 dBm min., for wideband
3rd Order Intercept: +20 dBm min., standard bandwidth
+17 dBm min., for wideband
Spurious: Non-Signal related:
-95 dBm max over freq band
Signal related:
-85 dBc max over freq band

Gain

Typical: 65 dB
Options: 40 dB, 50 dB, 60 dB
Ripple: 1 dB p-p max per 36 MHz segment
Temperature Compensated Gain Variation (optional):
 ± 0.5 dB max over frequency band

Environmental Specifications

Operating Temp: -40 to +60 °Celsius
Relative Humidity: Up to 100% condensation
and frost
MTBF: >270,000 hours

Block Diagram

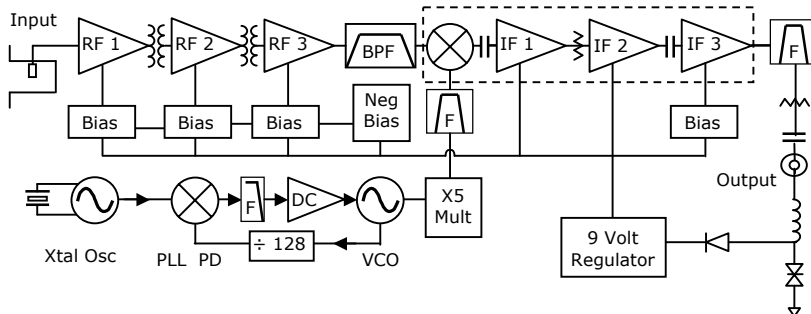

Power

DC Input: 12 to 24 VDC, 220 mA nominal
Filtering: Transient, over and reverse voltage protected

Mechanical Specifications

Size: 125 x 60 x 41 mm
Weight: 200 grams
Paint: Brilliant White Enamel

Orbital Research Ltd. designs and builds products for satellite communications applications. Orbital website: www.orbitalresearch.net. Copyright © 2010 Genie in the Bottle Enterprises Inc. All rights reserved. Specifications subject to change without notice.

